



CONTENTS:

1. SAFETY PRECAUTIONS AND PROCEDURES	1
1.1. Preliminary	2
1.2. During Use	2
1.3. After Use	2
1.4. Definition of measuring (overvoltage) category	3
2. GENERAL DESCRIPTION	3
3. PREPARATION FOR USE	4
3.1. Initial	4
3.2. Supply Voltage	4
3.3. Calibration	4
3.4. Storage	4
4. OPERATING INSTRUCTIONS.....	5
4.1. Instrument Description.....	5
4.1.1. Commands description.....	5
4.1.2. Alignment marks.....	5
4.1.3. Use of rubber test leads holster	6
4.1.4. AUTO POWER OFF function	6
4.2. Function key description.....	6
4.2.1.  key: enable/disable backlight	6
4.2.2. D-H key: HOLD function.....	6
4.2.3. SELECT key: select according to function range indication on the clamp meter.	6
4.2.4. R-H key:	6
4.3. Description of Rotary Switch Function.....	7
4.3.1. AC/ DC Voltage measurement	7
4.3.2. AC/DC uA current measurement.....	8
4.3.3. AC Current measurement	8
4.3.4. Resistance measurement.....	9
4.3.5. Continuity Test	10
4.3.6. Capacitance measurement	11
4.3.7. Temperature measurement.....	12
5. MAINTENANCE	12
5.1. General information	12
5.2. Battery replacement	12
5.3. Fuse replacement.....	13
5.4. Cleaning	13
6. TECHNICAL SPECIFICATIONS	13
6.1. Characteristics.....	13
6.1.1. Safety	15
6.1.2. General data.....	15
6.2. Environmental conditions	15
6.2.1. Climatic conditions	15
6.2.2. EMC	15
6.3. Accessories	15
6.3.1. Standard accessories.....	15

1. SAFETY PRECAUTIONS AND PROCEDURES

This apparatus conforms to safety standard EN 61010, relating to electronic measuring instruments. For your own safety and that of the apparatus, you must follow the procedures described in this instruction manual and especially read all the notes proceeded by the symbol  carefully.

	WARNING
	If instrument is used in way don't conform to prescriptions of this user's manual, all considered safety protection maybe damaged.

Take extreme care for the following conditions when measuring:

- Do not measure voltage, current under humid or wet environment.
- Do not operate the meter under the environment with explosive gas (material), combustible gas (material), steam or filled with dust.
- Do not touch the circuit under test if no measurement is being taken;
- Do not touch exposed metal parts, unused terminals, circuits and so on;
- Do not use the instrument if it seems to be malfunctioning (i.e. if you notice deformations, breaks, leakage of substances, absence of segments on the display and so on);
- Be careful when you measure voltages exceeding 20V as you may risk electrical shocks.
- Take care not to allow your hand to pass over the Safety Guard (see Fig.1, pos.2) on current measurements and voltage measurements using the holster.

The followings symbols are used:



Caution: Refer to the instruction manual. Incorrect use may damage the apparatus or its components.



Danger high voltage: risk of electric shock.



Double insulated meter



AC/DC Voltage or Current.



DC Voltage or Current.



Application around and removal from hazardous live conductors is permitted

1.1. PRELIMINARY

- This apparatus has been designed for use in an environment of pollution degree 2.
- It can be used for **CURRENT**, **VOLTAGE** and **FREQUENCY** measurements on installations of surge voltage category III up to 600 V, voltage between Phase and Earth (fixed installations) and for current measures up to 400A.
- This meter is not available for non-sine wave AC signals.
- You must comply with the usual safety regulations aimed at:
 - ◆ Protecting you against the dangerous electric current.
 - ◆ Protecting the instrument against an incorrect operation.
- Only the leads supplied with the instrument guarantee compliance with the safety standard. They must be in a good condition and they must be replaced, if necessary with an identical model.
- Do not test or connect to any circuit with voltage or current exceeding the specified overload protection.
- Do not perform any test with environmental condition exceeding the limits indicated in paragraphs 6.2.1.
- Check if the batteries are installed correctly.
- Prior to connecting the test probes to the installation, check that the function selector is positioned on the required measurement.
- Check if the LCD and the range indicator show the same as the function desired.

1.2. DURING USE

Read the recommendations that follow and the instructions in this manual:

	WARNING
	Non compliance with the warnings and/or the instructions for use may damage the apparatus and/or its components or injure the operator.

- Remove the clamp jaw from the conductor or circuit under test before changing the range.
- When the tester is connected to the measuring circuits, do not touch any unused terminals.
- Do not measure resistance in the presence of external voltages. Even if the circuit is protected, excessive voltage could cause the instrument to malfunction.
- When measuring current with the clamp jaws, first remove the test leads from the instrument's input jacks.
- When measuring current, any other source near the clamp jaw could affect its accuracy.
- When measuring current, always put the conductor to be tested in the middle of the clamp jaw to obtain the most accurate reading as referred into paragraph 4.1.2.
- While measuring, if the value remains unchanged check if the HOLD function is enabled.

1.3. AFTER USE

- Once the measurements are completed, turn the rotary switch to OFF.
- If you expect not to use the instrument for a long period of time remove the batteries.

1.4. DEFINITION OF MEASURING (OVERVOLTAGE) CATEGORY

The norm EN 61010: Safety requirements for electrical equipment for measurement, control and laboratory use, Part 1: General requirements, defines what a measuring category, usually called overvoltage category, is.

Circuits are divided into the following measurement categories:

- **Measurement category IV** is for measurements performed at the source of the low-voltage installation.
Examples are electric meters and measurements on primary overcurrent protection devices and ripple control units.
- **Measurement category III** is for measurements performed in a building installation.
Examples are measurements on distribution boards, circuit breakers, wiring, including cables, bus-bars, junction boxes, switches, socket-outlets in the fixed installation, and equipment for industrial use and some other equipment, for example, stationary motors with permanent connection to fixed installation.
- **Measurement category II** is for measurements performed on circuits directly connected to the low voltage installation.
Examples are measurements on household appliances, portable tools and similar equipment.
- **Measurement category I** is for measurements performed on circuits not directly connected to MAINS.
Examples are measurements on circuits not derived from MAINS, and specially protected (internal) MAINS-derived circuits. In the latter case, transient stresses are variable; for that reason, the norm requires that the transient withstand capability of the equipment is made known to the user.

2. GENERAL DESCRIPTION

Thanks to a new development concept assuring double insulation as well as compliance with category III up to 600V you can rely on utmost safety conditions.

This instrument can perform the following measurements:

- AC current (I_{AC}).
- AC uA current (I_{AC}).
- DC uA current. (I_{DC}).
- AC voltage (V_{AC}).
- DC voltage (V_{DC}).
- DC current (I_{DC}).
- Resistance.
- Continuity Test.
- Capacitance.
- Temperature

Each of these functions can be selected by means of a 7-position rotary switch, including an OFF position. There are also the following buttons: "D-H", "R-H / ", "SELECT" and "ZERO". For their use please see paragraph 0. The selected quantity appears on a high-contrast display with unit and function indication.

3. PREPARATION FOR USE

3.1. INITIAL

This instrument has been checked mechanically and electrically before shipment. All precautions have been taken to assure that the instrument reaches you in perfect condition.

However, it is advisable to carry out a rapid check in order to detect any possible damage, which might have occurred in transit.

Check the accessories contained in the packaging to make sure they are the same as reported in paragraph 6.3.1.

3.2. SUPPLY VOLTAGE

The instrument is battery supplied; it use two batteries model 1.5V LR03 included in packaging. The batteries autonomy is about 100 hours.

The symbol "" appears when the batteries are nearly discharged. In this case, replace them following the instructions in paragraph 5.2.

3.3. CALIBRATION

The tester complies with the accuracy specifications listed in this manual and such compliance is guaranteed for one year, afterwards the tester may need recalibration.

3.4. STORAGE

In order to guarantee the accuracy of the measurements, after a period of storage in an extreme environmental condition, wait for the apparatus returns to normal measuring conditions (see environments specifications paragraph 6.2.1).

4. OPERATING INSTRUCTIONS

4.1. INSTRUMENT DESCRIPTION

4.1.1. Commands description

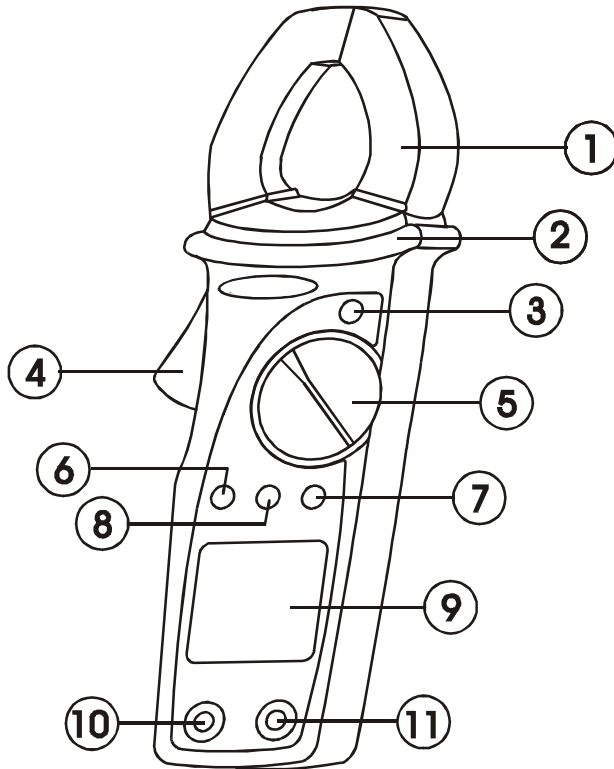

LEGEND:

- 1. Inductive clamp Jaw
- 2. Safety guard
- 3. Data hold
- 4. Jaw Trigger
- 5. Rotary Range Selector
- 6. SELECT Button
- 7. Backlight display button
- 8. Range hold button
- 9. LCD
- 10. COM Jack
- 11. + Jack

Fig. 1: Instrument description

4.1.2. Alignment marks

Put the conductor within the jaws at the intersection of the indicated marks as close as possible (see Fig. 2) in order to meet the meter accuracy specifications.

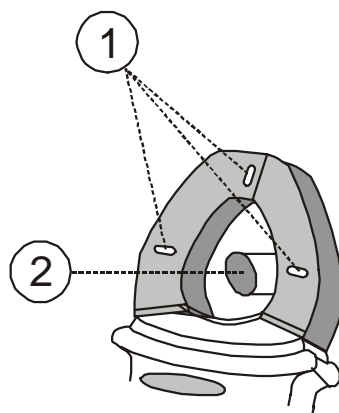

LEGEND:

- 1. Alignment marks.
- 2. Conductor.

Fig. 2: Alignment marks

4.1.3. Use of rubber test leads holster

One of the accessories is a rubber holster that, inserted on the clamp, can hold one of the two test leads, like showed in Fig. 3

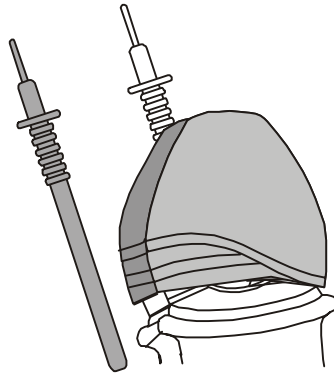



Fig. 3: Use of rubber test lead holster

This rubber holster has a very practical use. It allows the user to perform the measurements with both test leads while, more easily, observing the value on the display at the same time.

4.1.4. AUTO POWER OFF function

In order to extend the battery life, the clamp switches off 30 minutes after the last rotary switch or button actuation.

When this function is enabled the symbol is  displayed.

To disable this function select the OFF position then rotate the selector to any position while the R-H key or  key is pressed.

Turning OFF and ON the clamp the AUTO POWER OFF will be re-enabled.

4.2. FUNCTION KEY DESCRIPTION

4.2.1. key: enable/disable backlight

Press this key you enable the display backlight to easy readings in dark environments. Press more than 1 second to disable backlight, which, however, it automatically OFF after 60 seconds.

4.2.2. D-H key: HOLD function

This key enables the HOLD function locking the measured value. The symbol " HOLD " is displayed when this function is enabled. To disable this function:

- The D-H key is pressed again.
- The position of the rotary switch is changed.

4.2.3. SELECT key: select according to function range indication on the clamp meter.

4.2.4. R-H key:

Manual ranging is allowed while the button is pressed, and the symbol MANU is shown on LCD, The auto ranging mode is activated again while pressing the button more than 2 seconds or setting the range

4.3. DESCRIPTION OF ROTARY SWITCH FUNCTION

4.3.1. AC/ DC Voltage measurement

WARNING	
	Maximum input for AC/DC Voltage measurements is 600V. Do not attempt to take any voltage measurement that exceeds the limits. Exceeding the limits could cause electrical shock and damage the clamp meter.

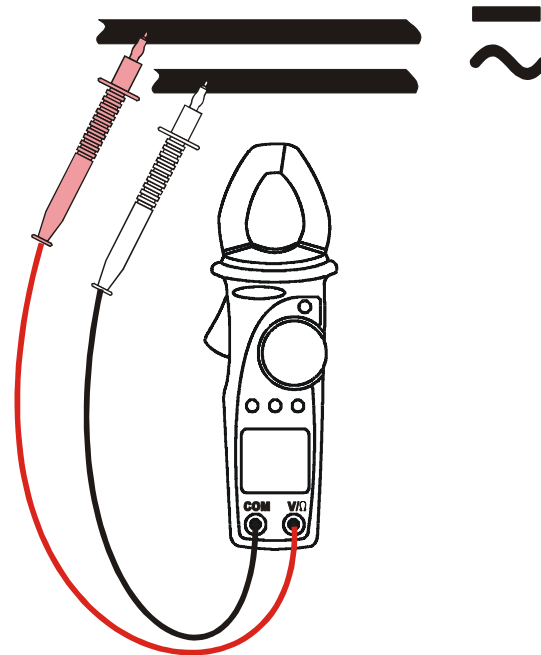

Fig. 4: Use of clamp for AC/DC voltage measures.

1. Select the “ $\approx V$ ” position of selector functions the V AC or VDC.
2. Insert the test leads into the jack, the red lead into “+” jack, and the black lead into the COM jack. Refer to Fig. 4.
3. Connect the test leads to the circuit, the voltage measured will be displayed with automatic detection of the appropriate range.
4. Press R-H key you can select manually the measurement ranges in cyclic order. Press R-H key 2 seconds to return to the AUTOMATIC range selection.
5. The “**O.L**” symbol means that the measured quantity is higher than the selected range. Press R-H key to select a higher range.
6. If reading the display is difficult, press D-H key to hold the obtained value. To exit from this function press D-H key again.

4.3.2. AC/DC uA current measurement

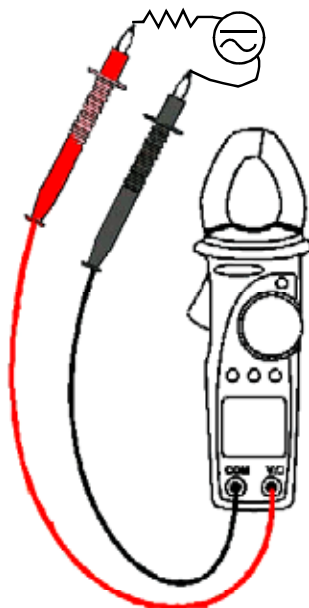



Fig. 5: Use of clamp for AC/DC uA current measures

1. Select the “ \approx uA” position of selector functions the uA AC or uA DC.
2. Insert the test leads into the jack, the red lead into “+” jack, and the black lead into the COM jack. Refer to Fig. 5.
3. Connect the test leads to the circuit, the voltage measured will be displayed with automatic detection of the appropriate range.
4. If the reading is preceded by the “-” sign check this indicate that Voltage polarity is reversed. Invert terminal leads for correct indication.
5. Press R-H key you can select manually the measurement ranges in cyclic order. Press R-H key 2 seconds to return to the AUTOMATIC range selection.
6. The “O.L” symbol means that the measured quantity is higher than the selected range. Press R-H key to select a higher range.
7. If reading the display is difficult, press D-H key to hold the obtained value. To exit from this function press D-H key again.

4.3.3. AC Current measurement

WARNING	
	<ul style="list-style-type: none"> • Make sure that all the test leads are disconnected from the meter's terminals for current measurement. • When measuring current, any strong current near the clamp jaws will affect the accuracy. • The instrument is not available for non-sine wave AC signal.

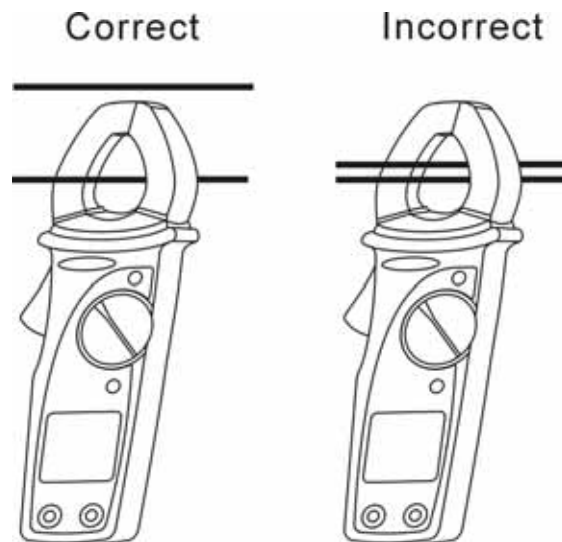

Fig. 6: Use of clamp during AC current measurement

1. Select “~A” position.
2. Open the clamp and put the tested conductor in the center of the clamp jaw (see paragraph 4.1.2), refer to Fig. 6.
3. The current measured will be displayed with automatic detection of the appropriate range.
4. Press R-H key you can select manually the measurement ranges in cyclic order. Press R-H key 2 seconds to return to the AUTOMATIC range selection.
5. The "O.L" symbol means that the measured quantity is higher than the selected range. Press RANGE key to select a higher range.
6. If reading the display is difficult, press D-H key to hold the obtained value. To exit from this function press D-H key again.

4.3.4. Resistance measurement



WARNING

Before taking any in circuit resistance measurement, remove power from the circuit being tested and discharge all the capacitors.

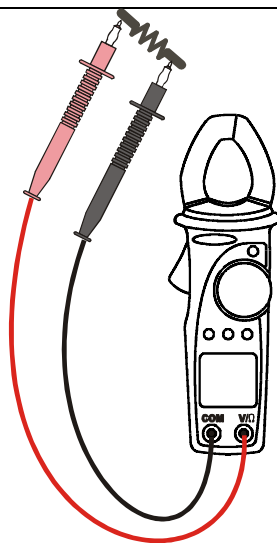

Fig. 7: Use of clamp for resistance measures.

1. Select the function " Ω/\rightarrow " or the function " Ω ".
2. Insert the test leads into the jacks. The red lead into "+" jack, and black lead into COM jack, as shown in Fig. 7.
3. Connect the test leads to the circuit, the voltage measured will be displayed with automatic detection of the appropriate range.
4. Press R-H key you can select manually the measurement ranges in cyclic order. Press R-H key 2 seconds to return to the AUTOMATIC range selection.
5. The "O.L" symbol means that the measured quantity is higher than the selected range. Press the R-H key to select a higher range.
6. If the reading is difficult, press the D-H key to hold the obtained value. To exit from this function press the D-H key again.

4.3.5. Continuity Test



Before taking any in circuit resistance measurement, remove power from the circuit being tested and discharge all the capacitors.

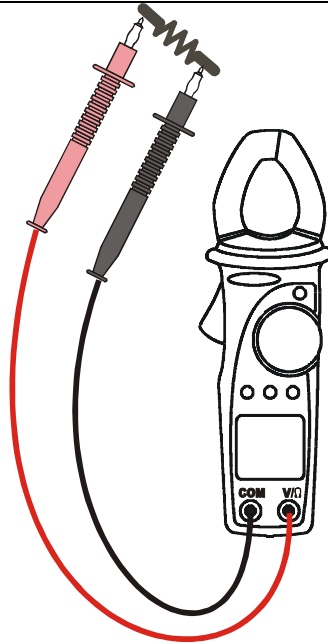



Fig. 8: use of clamp for continuity measure

1. Select the Ω/\rightarrow function or the " \rightarrow " function.
2. Insert the test leads into the jacks, the red lead into "+" jack, and black lead into COM jack, as shown in Fig. 8.
3. Connect the test leads to the circuit, the resistance will be displayed while the buzzer sounds when the resistance value is lower than 40Ω approximately.

4.3.6. Capacitance measurement

WARNING	
	<p>Before measuring the capacitor, please be sure to remove power from the circuit being tested and discharge all the capacitors. Before discharge of voltage from the capacitor, please note the safe discharge is to use a 100K resistor by means of parallel connection on the both ends of the capacitor.</p>

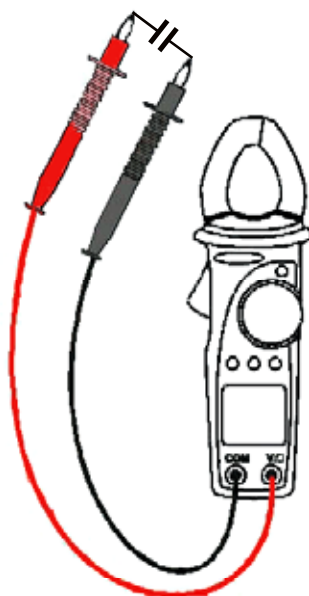



Fig. 9: use of clamp for continuity measure

1. Select “” range.
2. Insert the test leads into the jacks. The red test lead plug into “+” jack, and the black test lead plug into COM jack, as shown in Fig.9.
3. Connect the two long ends of test leads waiting for measuring capacitance (parallel connection with the circuit waiting for testing).
4. For measuring if capacitor is electrolytic capacitor or polarity capacitor, red test lead must be connected to positive (+) end, black test lead to the negative(-) end.
5. Read the capacitance value waiting for testing from LCD.
6. When use 4nF range, please note the value measured is the capacitance value waiting for testing plus capacitance value on the circuit of the meter, if intend to know the capacitance waiting for testing must be deducted the capacitance value on the circuit of the meter such as: LCD display value is 195PF, the capacitance value on the circuit of the meter is 45PF, and the capacitance waiting for testing is 150PF.

4.3.7. Temperature measurement

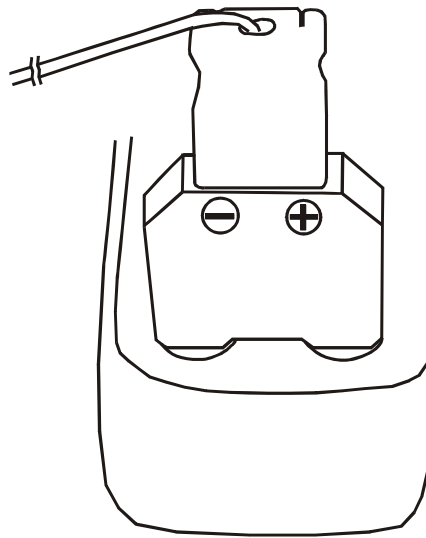

Fig. 10: use of clamp for temperature measure

1. Select "TEMP" range.
2. Insert the test leads into the jacks, the red test lead play into "+" jack, and the black test lead plug into COM jack, as shown in Fig.10.
3. Connect the two long ends of test leads to the desired circuit, then reading will be displayed.
4. Press DATA HOLD button to hold the value when takes the resistance measurement, if it's necessary.

5. MAINTENANCE

5.1. GENERAL INFORMATION

1. This digital clamp meter is a precision instrument. Whether in use or in storage, please do not exceed the specifications to avoid any possible damage or danger during use.
2. Do not place this meter in high temperature and/or humidity or expose to direct sunlight.
3. Be sure to turn the meter off after use. For long term storage, remove the batteries to avoid leakage of battery fluid that can damage the internal components.

5.2. BATTERY REPLACEMENT

When LCD displays the symbol "", replace the batteries.



WARNING

Only experts and trained technicians should perform this operation. Remove the test leads or the conductor under test before replacing the batteries.

1. Set range switch to the OFF position.
2. Remove the test leads.
3. Remove the screw from the battery cover.
4. Remove the battery cover.
5. Remove the low batteries.
6. Replace them with new of then same type (1.5V AAA).
7. Replace the battery cover and screw.
8. Use the appropriate battery disposal methods for your area.

5.3. FUSE REPLACEMENT

	WARNING
	<p>The fuse is an integral part of the overvoltage protection. When fuse replacement is necessary, See specifications for the correct type, size and capacity. Using any other type of fuse will void the overvoltage protection rating of the unit.</p> <p>Failure to observe this warning can result in severe injury or death.</p>

1. Disconnect the unit from the circuit. Turn the unit OFF.
2. Remove the screws from the battery cover. Remove the battery cover.
3. Reinstall the fuse.

5.4. CLEANING

For cleaning the instrument use a soft dry cloth. Never use a wet cloth, solvents or water, etc.

6. TECHNICAL SPECIFICATIONS

This product conforms to the prescriptions of the European directive on low voltage 73/23/EEC (LVD) and to EMC directive 89/336/EEC, amended by 93/68/EEC.

6.1. CHARACTERISTICS

Accuracy is indicated as [% of reading + digit number]. It is referred to the following reference conditions: 23°C ± 5°C with RH <75%.

DC uA (Auto/Manual)

Range	Resolution	Accuracy	Burden Voltage	Overload Protection
400uA	0.1uA	± (1.0%+2)	500uV/uA	0.2A/250V Fuse
4000uA	1uA			

AC uA (Auto/Manual)

Range	Resolution	Accuracy 50Hz~60 Hz	Burden Voltage	Overload Protection
400uA	0.1uA	± (1.2%+3)	500uV/uA	0.2A/250V Fuse
4000uA	1uA			

ACA (Auto/Manual)

Range	Resolution	Accuracy 50Hz~60 Hz	Overload Protection
40A	0.01A	± (2.0%+10)	600A rms (60 second)
400A	0.1A		

DCV (Auto/Manual)

Range	Resolution	Accuracy	Input Impedance	Overload Protection
4V	1mV	$\pm (0.8\%+2)$	11M	DC/AC 660V rms
40V	10mV		10M	
400V	100mV			
600V	1V	$\pm (1.0\%+2)$		

ACV (Auto/Manual)

Range	Resolution	Accuracy 50Hz~500 Hz	Input Impedance	Overload Protection
4V	1mV	$\pm (1.0\%+3)$	11M Ω	DC/AC 660V rms
40V	10mV		10M Ω	
400V	100mV			
600V	1V	$\pm (1.2\%+3)$		

Resistance (Auto/Manual)

Range	Resolution	Accuracy	Max. Open Voltage	Overload Protection
400 Ω	0.1 Ω	$\pm(0.8\%+5)$	about -1.5V _{DC}	DC/AC 600V rms (60Second)
4K Ω	1 Ω	$\pm(0.8\%+2)$	About-0.45V _{DC}	
40K Ω	10 Ω			
400K Ω	100 Ω			
4M Ω	1K Ω			
40M Ω	10K Ω	$\pm(3\%+2)$		

Continuity Test

Range	Buzzer	Max. Open Voltage	Overload Protection
·))	below 25 Ω	About-1.5V _{DC}	600V rms

Capacitance (Auto/Manual)

Range	Resolution	Accuracy	Overload Protection
4nF	1pF	$\pm(3\%+10)$	DC/AC 600V rms (60Second)
40nF	10pF		
400nF	100PF		
4uF	1nF		
40uF	10nF		
400uF	100nF		
4mF	1uF	$\pm(5\%+10)$	

Temperature:optional temp.probe : K(CA) type.

Range	Resolution	Accuracy
	1	-50 ~ 0 $\pm(1.8\%+2)$) 0 ~ 500 $\pm(1.0\%+2)$) 500 ~ 1200 $\pm(1.8\%+2)$)
	1	-58 ~ 32 $\pm(1.8\%+3)$) 32 ~ 932 $\pm(1.0\%+3)$) 932 ~ 1999 $\pm(1.8\%+3)$)

The tolerance of temp. Probe excluded.

Max.input voltage for thermocouple : DC60V,AC24V

6.1.1. Safety

Comply with:	EN 61010-1(2001) and EN 61010-2-032(2002)
Insulation:	Class 2, double reinforced insulation
Pollution:	Level 2
For inside use, max height:	2000m
Over voltage:	CAT III 600V (between ground and input terminal)

6.1.2. General data**Mechanical characteristics**

Size:	205(L) x 64 (W) x 39(H)mm
Weight (including battery):	about 280g
Jaws opening:	30mm
Max conductor size:	30mm

Supply

Batteries type:	2 batteries 1.5V LR03 AAA.
Low battery indication:	Symbol "  " is displayed when battery level is too low.
Battery life:	About 100 hours.

Display

Characteristics:	3 ³ / ₄ LCD with maximum reading 3999 units plus decimal point signs plus backlight
Sample rate:	2 times/sec.

6.2. ENVIRONMENTAL CONDITIONS**6.2.1. Climatic conditions**

Reference temperature:	23° ± 5°C
Operating temperature:	5 ~ 40 °C
Operating humidity:	0~ 80% RH
Storage temperature:	-10 ~ 60 °C
Storage humidity:	0 ~ 80% RH

6.2.2. EMC

This apparatus was designed in accordance with EMC standards in force and its compatibility has been tested in accordance EN61326 (1997) + A1 (1998) + A2 (2001).

6.3. ACCESSORIES**6.3.1. Standard accessories**

The accessories contained inside the packaging are the following:

- Instrument.
- Test leads.
- Rubber test lead holster (HT4000)
- User's manual.
- Carrying case.
- Batteries.
- 0.2A/250V F fuse, fast min interrupter rating 1500A, 5x20mm.